

# PULSED LOW ENERGY ELECTRON SOURCES FOR MATERIAL SURFACE MODIFICATION

S. A. Korenev and R. P. Johnson

Muons, Inc., 552 N. Batavia Avenue,  
Batavia, IL 60510 USA

## Abstract

Two conceptual designs of pulsed low energy electron sources (100 to 1000 ns and 1 to 50 keV) are investigated for the modification of surface properties of materials. The first design uses plasma formed on a dielectric, which is excited by a high-frequency pulse generator. The second uses a Micro-Channel Plate (MCP) to form the cathode plasma. Experimental results are presented on the formation of pulsed high-current, low-energy electron beams with large cross-sectional area.

## I. INTRODUCTION

Pulsed electron beams are used to modify materials by depositing energy in them [1]. To effectively change the surface of a material, the main requirement is that the beam energy must be dissipated adiabatically in a thin layer of bulk material in a short time. The adiabatic condition is defined by [2]:

$$t_{beam} \leq t_{therm} = \frac{2 \cdot h^2 \cdot \rho \cdot C}{\lambda}, \quad (1)$$

where:  $h$  is the penetration depth of the electron beam in the irradiated sample and  $\rho$ ,  $C$ , and  $\lambda$  are the density, heat capacity, and heat conductivity of modified material.

Electron beam irradiation for surface modification of materials has many applications such as for superconductors, semiconductors, and polymers.

Pulsed electron beams for this technology must have large cross section and good current density uniformity. A plasma cathode is often used to accomplish these goals. The generation of a high current electron beam with low kinetic energy of 1.0 to 50.0 keV and nanosecond pulse duration is not simple. A beam with these parameters is the goal of the R&D effort described here.

## II. ELECTRON BEAM REQUIREMENTS

The main parameter for surface modification of materials is the delivered dose, which is defined [3]:

$$D = \frac{E}{m}, \quad (2)$$

where:  $E$  is the deposited beam energy into a layer of material of mass  $m$ . For a pulsed electron beam [4]:

$$D = \frac{E}{m} = \frac{U \cdot j \cdot t_{beam} \cdot N}{\rho \cdot h}, \quad (3)$$

where:  $U$  is the accelerating voltage,  $j$  is the beam current density,  $t_{beam}$  is the pulse duration of the electron beam, and  $N$  is the number of beam pulses.

The dissipation of energy leads to heating the material. The gradient of temperature in this layer can be calculated by:

$$T = \frac{U \cdot I \cdot t_{beam}}{0.8 \cdot D \cdot h \cdot C \cdot \rho}, \quad (4)$$

where:  $U$  is the accelerating voltage,  $I$  is the beam current,  $t_{beam}$  is the beam pulse duration,  $D$  is the beam diameter,  $h$  is the depth of penetration for the electron beam in the irradiated sample  $\rho$  is the density, and  $C$  is the heat capacity of the modified material.

A typical distribution of absorbed dose and temperature gradient, where only one side of the material is irradiated, is shown in Figure 1.

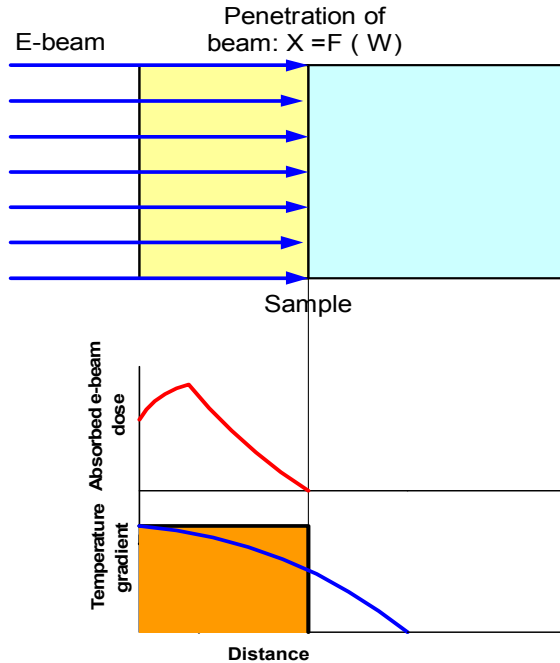


Figure1. Distribution of absorbed dose and temperature gradient as a function of depth of sample for the typical method of irradiation.

### III. EXPERIMENTAL SETUP

A diagram of the pulsed electron source is shown in Figure 2.

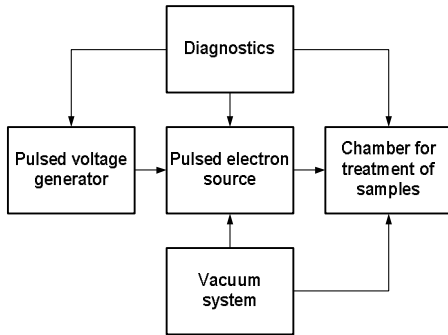


Figure 2. Block-diagram of the experimental setup.

For the plasma electron source, the vacuum has a residual gas pressure of  $10^{-5}$  Torr. Diagnostic devices include a current transformer, Faraday cups, film dosimeters, and high voltage probes. The treatment chamber contains sample holders and radiation diagnostics. Different pulsed high voltage generators have been used for electron beam extraction, where the main parameters have been:

- voltage from 1.0 to 50.0 kV
- pulse duration from 100 to 1000 nsec
- stored energy from 1 to 100 J.

The electrical schematic and the corresponding picture of the 1 to 20 kV, 1000 ns generator is presented in Figures 3 and 4. Another generator with voltage 1-50 kV with a different type of load used a Shenderovich circuit [5], shown in Figure 5, which also had a 1000 nsec maximum pulse duration. Depending on the voltage, the pulse duration was regulated by two methods: a) by a resistor parallel to the electron source and b) a gap between cathode and anode.

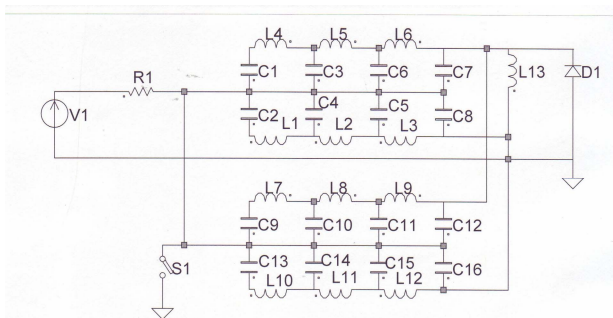


Figure 3. Electrical diagram of 1 to 20 KV pulse generator.

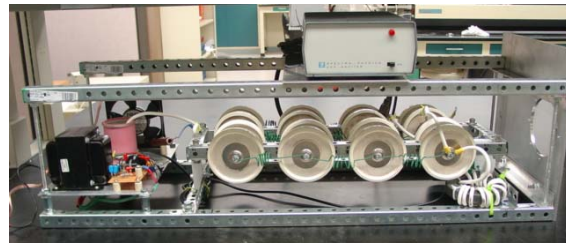


Figure 4. Picture of 1 to 20 kV pulse generator.

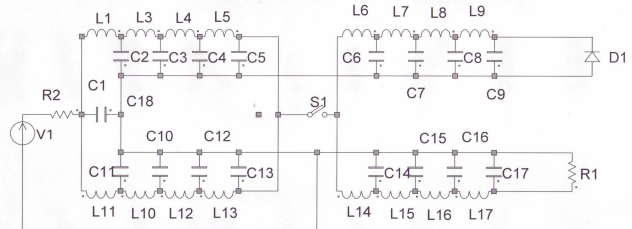


Figure 5. Diagram of 1-50 kV pulse generator.

### IV. THE PLASMA ELECTRON SOURCE

Electrical discharge on a dielectric surface has been developed using passive [6] and active [7] plasma cathodes. The general structure of a plasma cathode is shown in Figure 6a and the implementation used here is presented in Figure 6b.

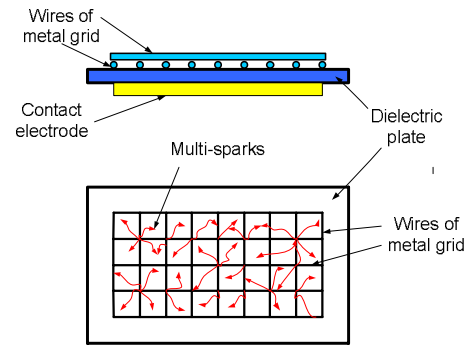


Figure 6a. The general structure of a plasma cathode with surface discharge on the dielectric (top) and sparks on the contact electrode (bottom).

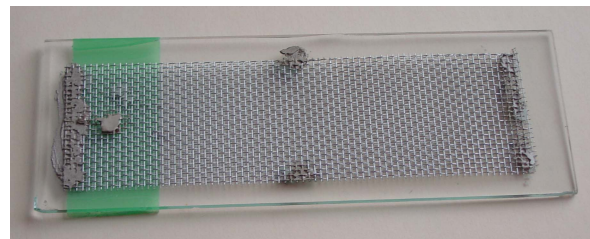
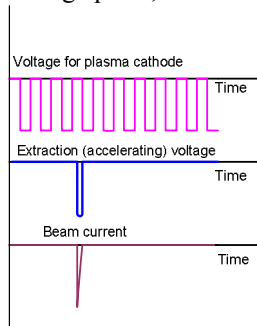


Figure 6b. Picture of cathode panel.

The main advantage of this type of electrical discharge on a dielectric is the large area of the generated plasma.

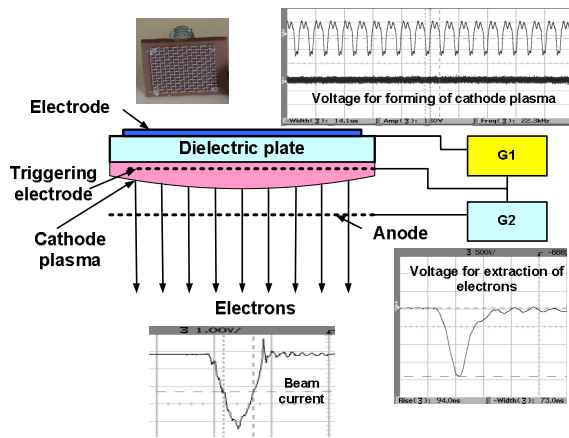
However in spite of progress in understanding the physical processes, there are still significant problems: the beam current jitter is about 50-200 nsec and the current non-uniformity is about 25-30%. Sparking between the metal grid contacts and the dielectric are main cause of these problems.

**Our new idea to stabilize the electron beam current from a plasma cathode** is to continuously excite the plasma with a 1 to 20 kHz voltage waveform to prepare it for the extraction voltage pulse, as shown in Figure 7.

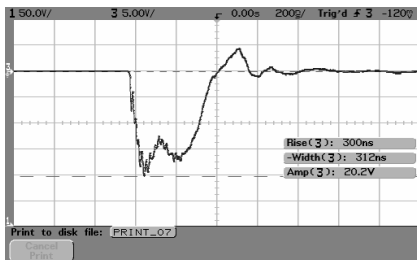


**Figure 7. New scheme of electron beam generation .**

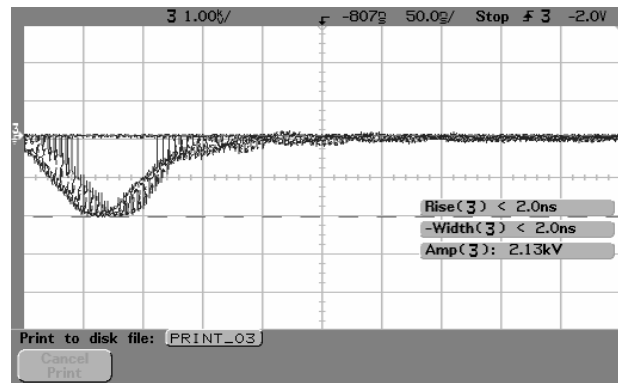
The experimental setup for plasma electron source studies is shown in Figure 8. The time stability and jitter of beam current is presented by waveforms on Figure 9 for 100 pulses and on Figure 10 for 100 nsec pulse duration.



**Figure 8. Experimental schematic.**



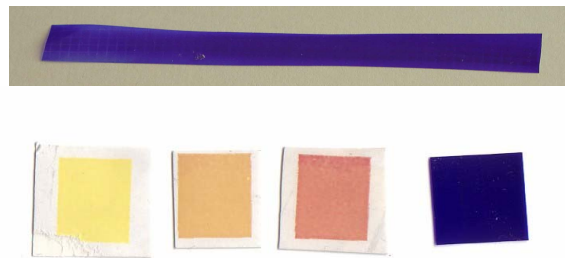
**Figure 9. Waveform stability as seen for 100 pulses.**



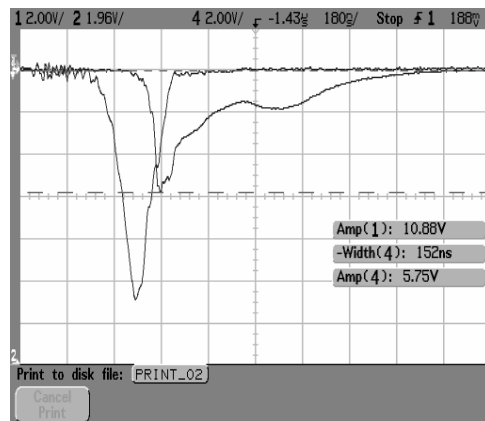
**Figure10. Jitter for a 100 nsec long extraction pulses.**

The uniformity of the electron beam was determined by FWT-50 film dosimeters [8] and color indicators. Typical film dosimeter pictures and color indicators are shown in Figure 11. Using these measurements of the absorbed dose, the dose uniformity over 200 mm is 7 to 10%.

Typical waveforms for voltage and beam current are shown in Figure 12. The typical beam current density in our experiments was 0.1 to 5 A/cm<sup>2</sup>.



**Figure 11. Images of film dosimeters and color indicators used to determine dose uniformity.**



**Figure 12. Typical waveforms for voltage (first trace) and beam current (second trace).**

## V. MCP ELECTRON SOURCE

A MCP can be used to generate electrons to form a cathode plasma. Further, as indicated in Figure 13, the dielectric properties of a MCP allow the use of a capacitor divider for voltage distribution.

The voltage on the MCP amplifies the electrons which form the cathode plasma. The voltage on the accelerating electrode extracts electrons from the cathode plasma.

An external UV or X-ray source initiates the primary electrons which are amplified by the MCP by a factor of  $10^5$  to  $10^6$ , as shown in Figure 14.

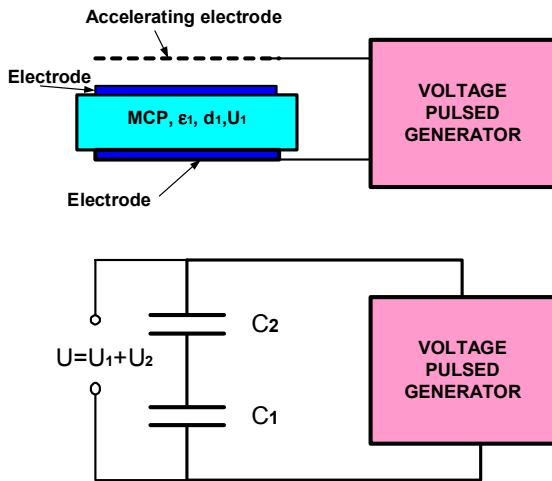


Figure 13. Capacitive voltage divider for a MCP electron source.

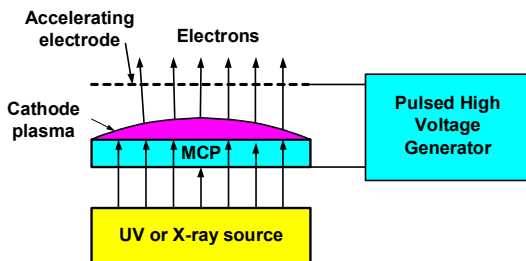


Figure 14. Principle of electron source with MCP plasma cathode.

The progress in MCP and UV and X-ray source technology has improved prospects for generating low

energy electron beams with large cross section. Experiments show that an MCP electron source with 50 cm diameter can achieve a current density of 2 to 5 A/cm<sup>2</sup> for voltage of 5 to 20 kV.

The main problem with the MCP cathode is a short life time for current density greater than 10 A/cm<sup>2</sup> at voltages up to 25 kV. A study of life time for MCP cathodes with 2A/cm<sup>2</sup> current density had a maximum of  $\sim 10^7$  pulses with 200 Hz repetition rate and 10 kV voltage. For high current density the MCP surface can be damaged by melting which leads to non-homogeneous beams with unacceptable current density variations. Early experiments [9, 10] with MCP-based plasma cathodes had very homogeneous current density with only 5% variation for voltage 100-300 kV and current density  $> 100$  A/cm<sup>2</sup>.

## V. CONCLUSIONS

For electron beam modification of materials:

1. The two designs described above achieve the required electron beam parameters (current, kinetic energy, pulse duration, uniformity)
2. These pulsed electron sources are simple in design and construction.

## VI. REFERENCES

- [1] S. Korenev, I. Korenev, "Nanosecond pulsed electron accelerators for radiation technologies", in Proc. 26<sup>th</sup> Power Modulator Symposium and High Voltage Workshop, San Francisco, CA, 2004, p.278-281.
- [2] S. Korenev, A. Perry, "Small pulsed electron-ion sources for radiation technologies and surface modification of materials". Vacuum, V. 47, 1996, p.1089-1993.
- [3] W.L. McLaughlin, A.W. Boyad, K.H. Chadwick, J.C.Mcdonald, A. Miller, Dosimetry of Radiation Processing, Teylor and Francis, New York, 1989.
- [4] S. Korenev, "Electron beam curing of composites". Vacuum, 2001, V.62, p. 233-236
- [5] G.A. Mesyats, Generation of nanosecond pulses. Sovetskoe Radio, Moscow, 1974.
- [6] S. A. Korenev, "The forming of electron beams in the high current diode". Communication of JINR No: 9-81-573, JINR, Dubna, 1981.
- [7] Y.E. Kreindel, Plasma electron source. Atomizdat, Moscow, 1977.
- [8] ASTM International Standards on Dosimetry for Radiation Processing.
- [9] S.A. Korenev, "Electron accelerator" Patent of Russian Federation No 1075937, Issued 1983.
- [10]. S.A. Korenev, "Design and investigations of pulsed electron and ion sources and their applications", Doctor Science Thesis, Joint Institute for Nuclear Research No: 9-94-350, JINR, Dubna, 1994.